

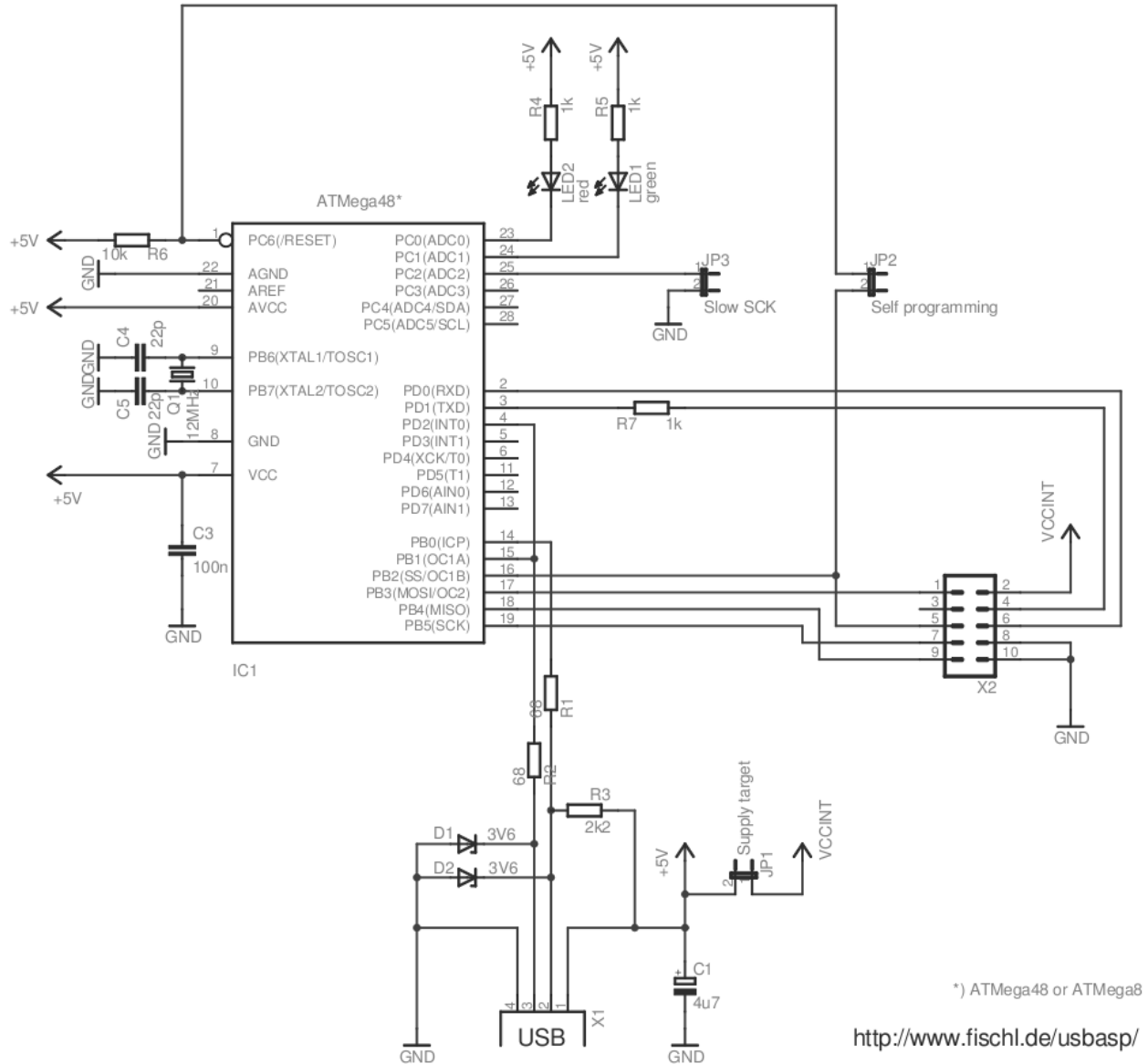

## Official Schematics



### My Target connections:

On the schematics above, here are the connections I made from the 10 pin connector to the target chips. **Don't leave any official connections out, this table is only a guide for once the connector is made.**

10 pin connector	Target
1	MOSI
2	VCC
5	RESET
7	SCK
8 and/or 10	GND
9	MISO

If the pin is not mentioned, is it not used.